



## Upgraded gyrotron components for enhanced thermomechanical performances

*F4E, EGYC (European GYROtron Consortium) and Thales have designed two high performances gyrotron subsystems: a thermo-compensated cathode and an adaptative mini-channel cooling system. These components have been used to enhance the performances of a high-power gyrotron and are now available for new applications in vacuum tubes, particle accelerators or electronics.*

### The Technologies

The ITER operation requires high power to be transferred into the plasma for the fusion conditions to be achieved. Thales, EGYC and F4E have developed a new gyrotron device that is able to provide powers larger than previous technologies in virtually continuous operation mode. Because of the high power involved, dedicated subsystems able to operate under high temperatures thanks to good thermomechanical properties have been created. Indeed, regular components were deformed during high-power operations, decreasing the efficiency.

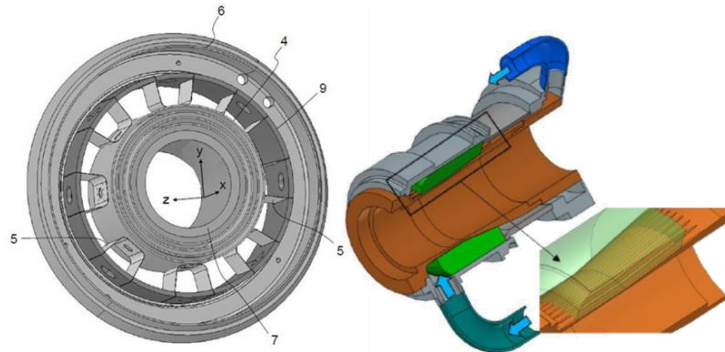

## Maximizing the gyrotron performance thanks to optimized thermomechanical properties patented components

The upgraded cathode ensures an isotropic thermomechanical deformation during the gyrotron operation to provide high quality beam properties, by maintaining the cathode position while limiting the heat flow. The mini-channel cooling system (**patent pending**) is an adaptative cooling circuit allowing increasing heat exchange while limiting thermo-mechanical stress and non-isotropic deformations of the cavity. This system allows to manage very high power while ensuring isotropic thermomechanical deformation of the cavity. The combination of these two subsystems leads to a consequent high power, high efficiency gyrotron.

## A better thermal behaviour for critical components in demanding electronics

Both the cathode and the cavity cooling system can be transferred into existing gyrotrons to increase their performances. Additionally, the cathode can be used in vacuum tubes and particles accelerators, in which cathodes need to be cooled while maintained in a precise position. The mini-channel cooling system can be transferred to any applications in electronics, for which specific components need to be effectively cooled down, like CPUs or amplifiers.

## Collaboration opportunities

The technology is available for direct use, technical adaptation for new applications or integration to existing gyrotron designs.

*Fusion for Energy*

*Email:*

[technologytransfer@f4e.europa.eu](mailto:technologytransfer@f4e.europa.eu)